



2024 13U Girls Provincial Championships

Saturday, May 4th and Sunday, May 5th
Dakota Community Centre



Pools & Round Robin Schedule

Pool A			Pool B			Pool C		
A1	Blazers 13U Inferno	1	B1	Phoenix 13U	2	C1	Westman 13U Wave	9
A2	Junior Bison 13U Gold	3	B2	Parkland Vipers 13U	4	C2	Jr. Pilots 13U Navy	11
A3	Junior Bison 13U Brown	5	B3	WinMan Storm	6	C3	Island Breeze 13U	13
A4	Bandits 13 Jolene	7	B4	Vision Elite 13U Black	8	C4	BVC 13U Bobcats	15
Pool D			Pool E			Pool F		
D1	BVC 13U Cougars	10	E1	Jr. Pilots 13U White	17	F1	Russell 13U	18
D2	Interlake Ice	12	E2	Selkirk Royals 13U White	19	F2	Junior Bison 12U Gold	20
D3	Selkirk Royals 13U Grey	14	E3	Junior Bison 12U Brown	21	F3	Vision Elite 13U Blue	22
D4	Bandits 13 Hannah	16	E4	Vision Elite 12U	23	F4	Westman 13U Wild	24

Saturday, May 4th											
Time	DCC Court 1			Time	DCC Court 2			Time	DCC Court 3		
9:00	A1	vs	A4	9:00	A2	vs	A3	9:00	C1	vs	C4
10:00	B1	vs	B4	10:00	B2	vs	B3	10:00	D1	vs	D4
11:00	A1	vs	A3	11:00	A2	vs	A4	11:00	C1	vs	C3
12:00	B1	vs	B3	12:00	B2	vs	B4	12:00	D1	vs	D3
1:00	A1	vs	A2	1:00	A3	vs	A4	1:00	C1	vs	C2
2:00	B1	vs	B2	2:00	B3	vs	B4	2:00	D1	vs	D2
Time	DCC Court 4			Time	DCC Court 5			Time	DCC Court 6		
9:00	C2	vs	C3	9:00	E1	vs	E4	9:00	E2	vs	E3
10:00	D2	vs	D3	10:00	F1	vs	F4	10:00	F2	vs	F3
11:00	C2	vs	C4	11:00	E1	vs	E3	11:00	E2	vs	E4
12:00	D2	vs	D4	12:00	F1	vs	F3	12:00	F2	vs	F4
1:00	C3	vs	C4	1:00	E1	vs	E2	1:00	E3	vs	E4
2:00	D3	vs	D4	2:00	F1	vs	F2	2:00	F3	vs	F4

2024 13U Girls Provincial Championships

Saturday, May 4th and Sunday, May 5th
Dakota Community Centre



Playoff Bracket - Round 1 (Saturday)

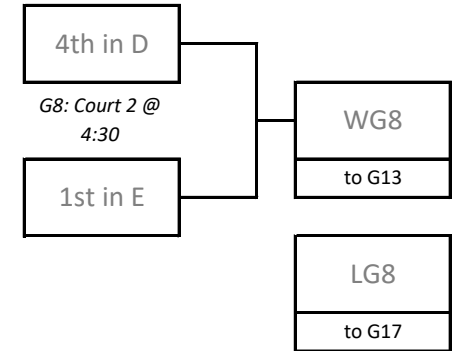
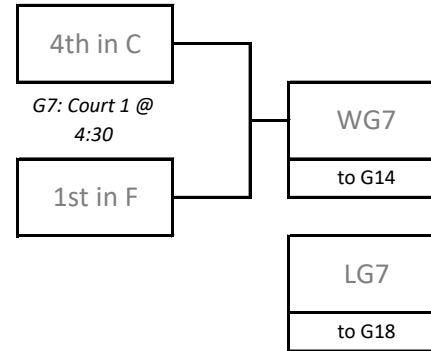
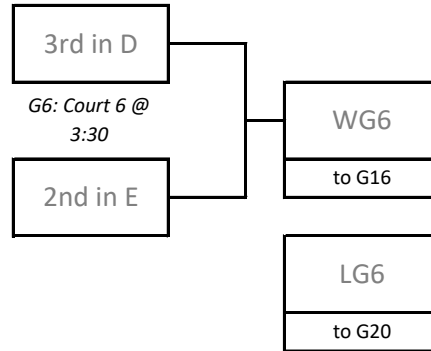
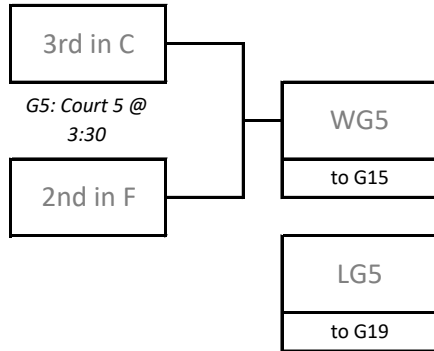
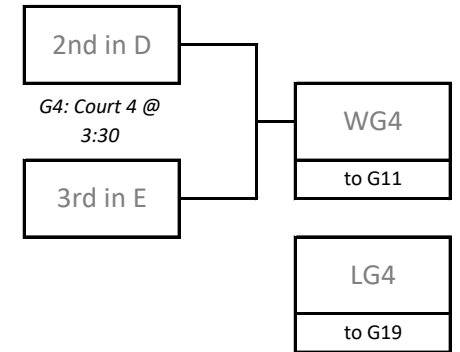
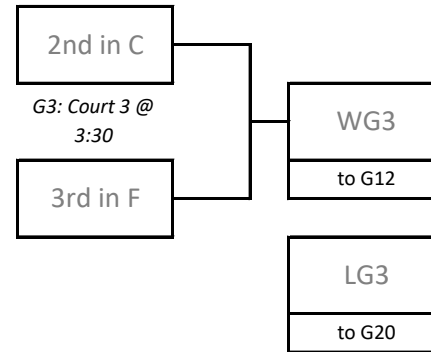
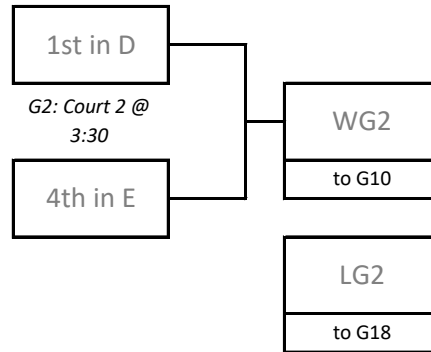
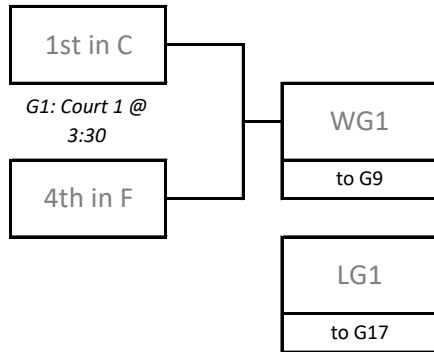

2024 13U Girls Provincial Championships

Saturday, May 4th and Sunday, May 5th
Dakota Community Centre



Playoff Bracket - Round 2 (Sunday)

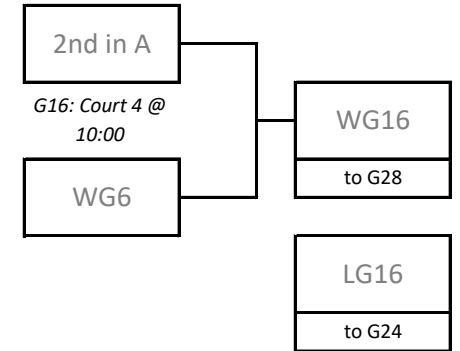
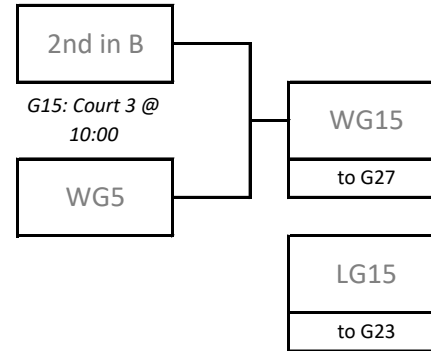
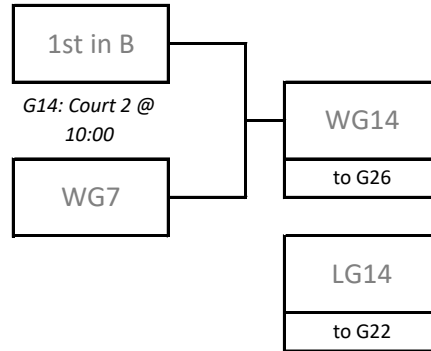
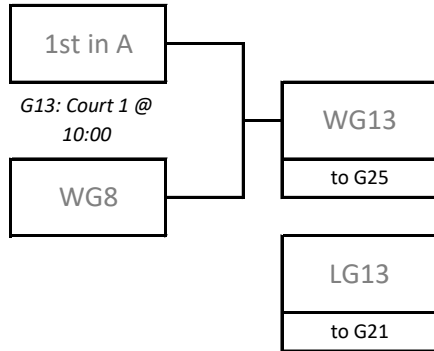
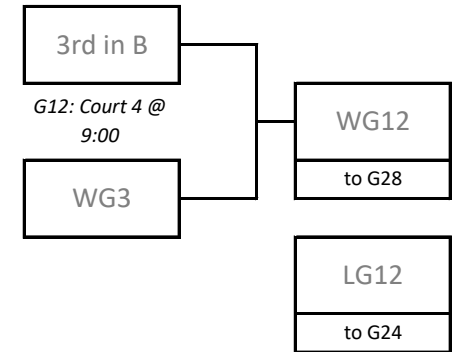
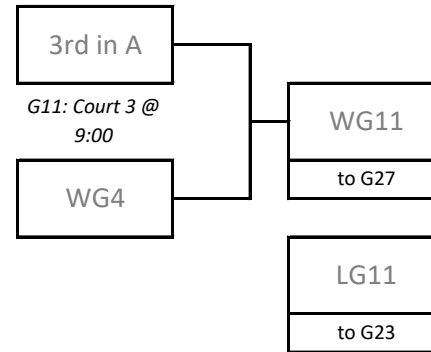
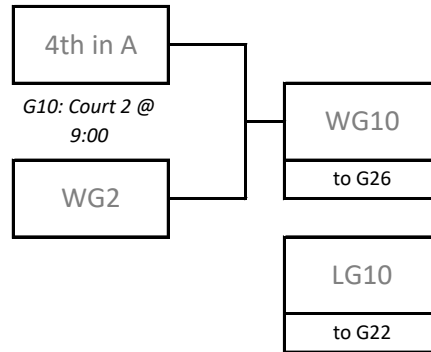
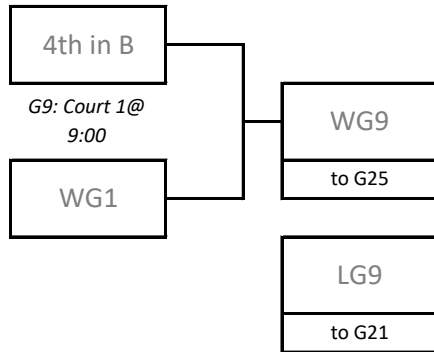

2024 13U Girls Provincial Championships

Saturday, May 4th and Sunday, May 5th
Dakota Community Centre



Playoff Bracket

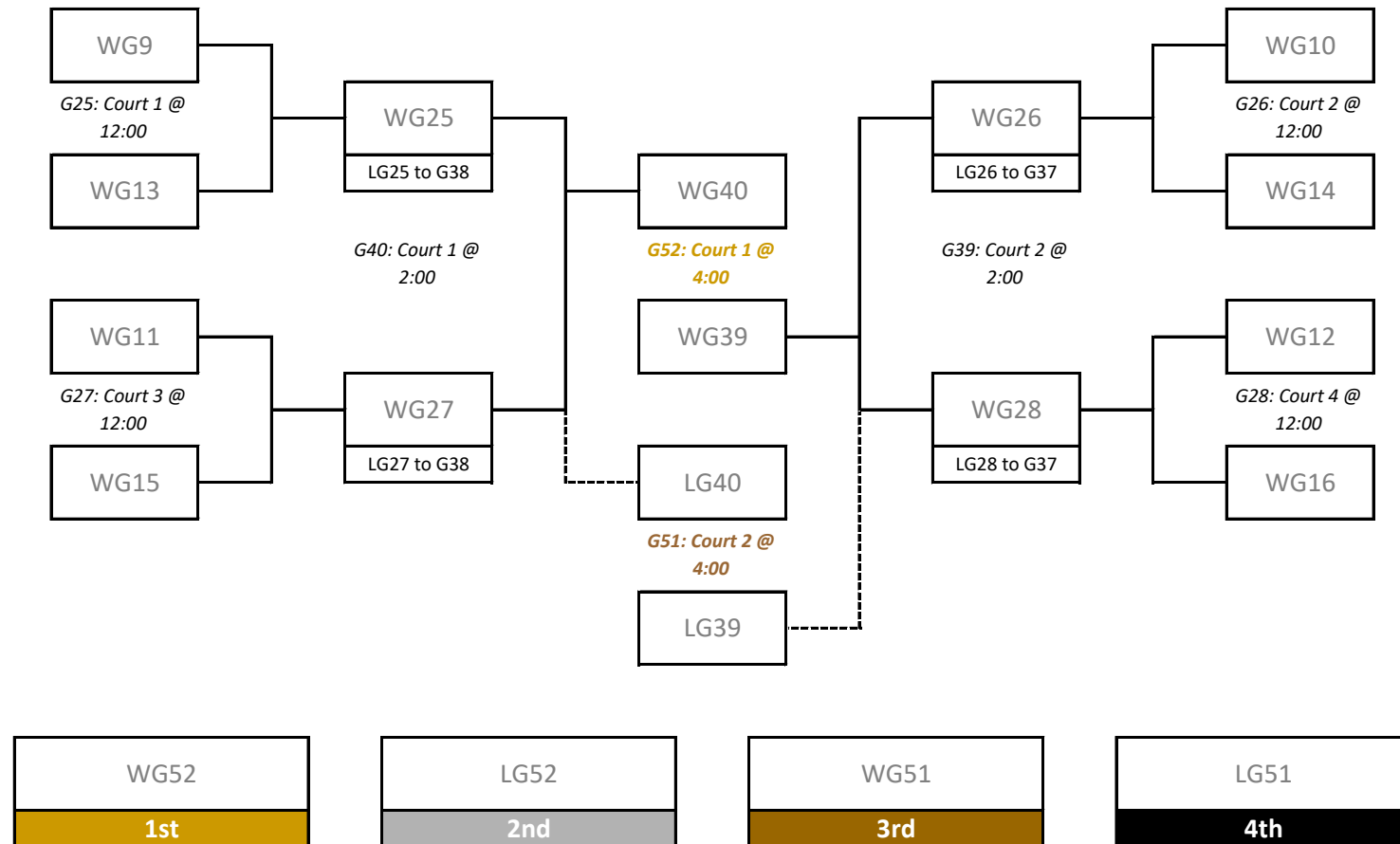

2024 13U Girls Provincial Championships

Saturday, May 4th and Sunday, May 5th
Dakota Community Centre



Playoff Bracket (5th-8th)

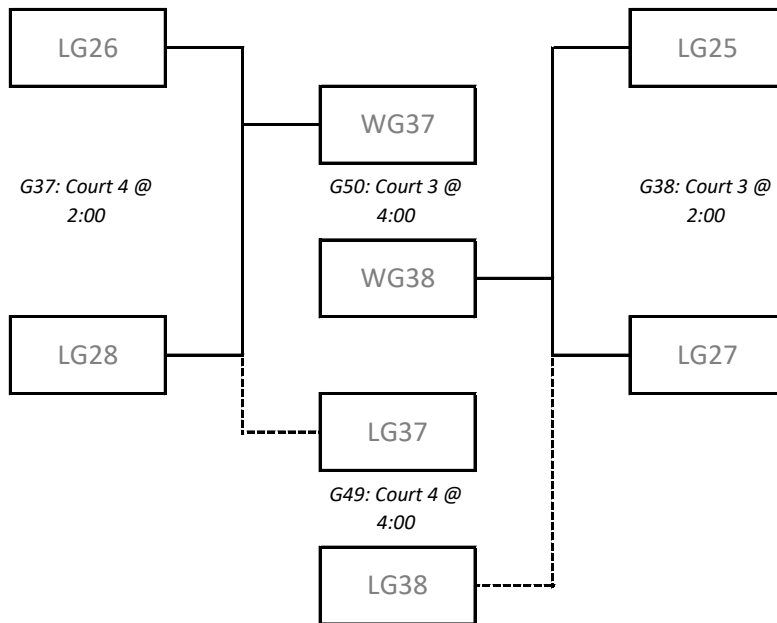

WG50
5th

LG50
6th

WG49
7th

LG49
8th

Playoff Bracket (13th-16th)

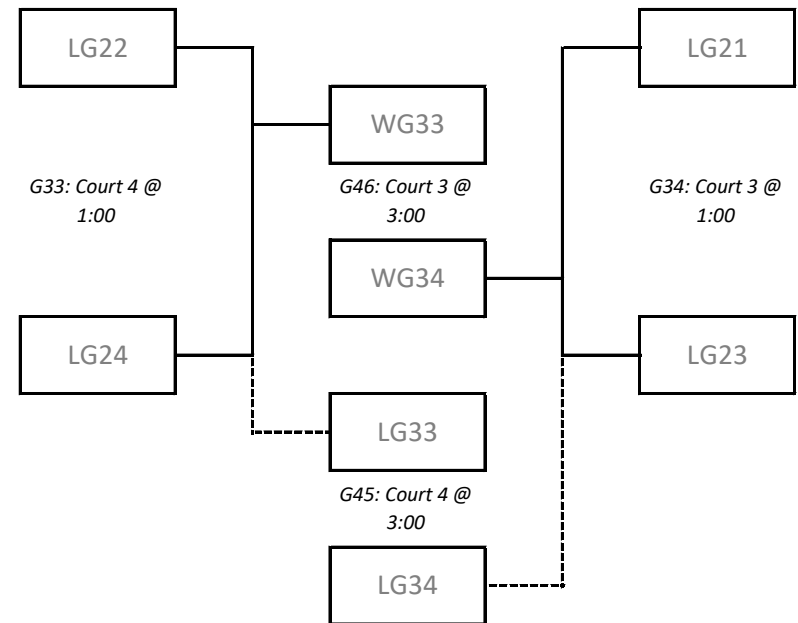

WG46
13th

LG46
14th

WG45
15th

LG45
16th

2024 13U Girls Provincial Championships

Saturday, May 4th and Sunday, May 5th
Dakota Community Centre



Playoff Bracket (9th-12th)

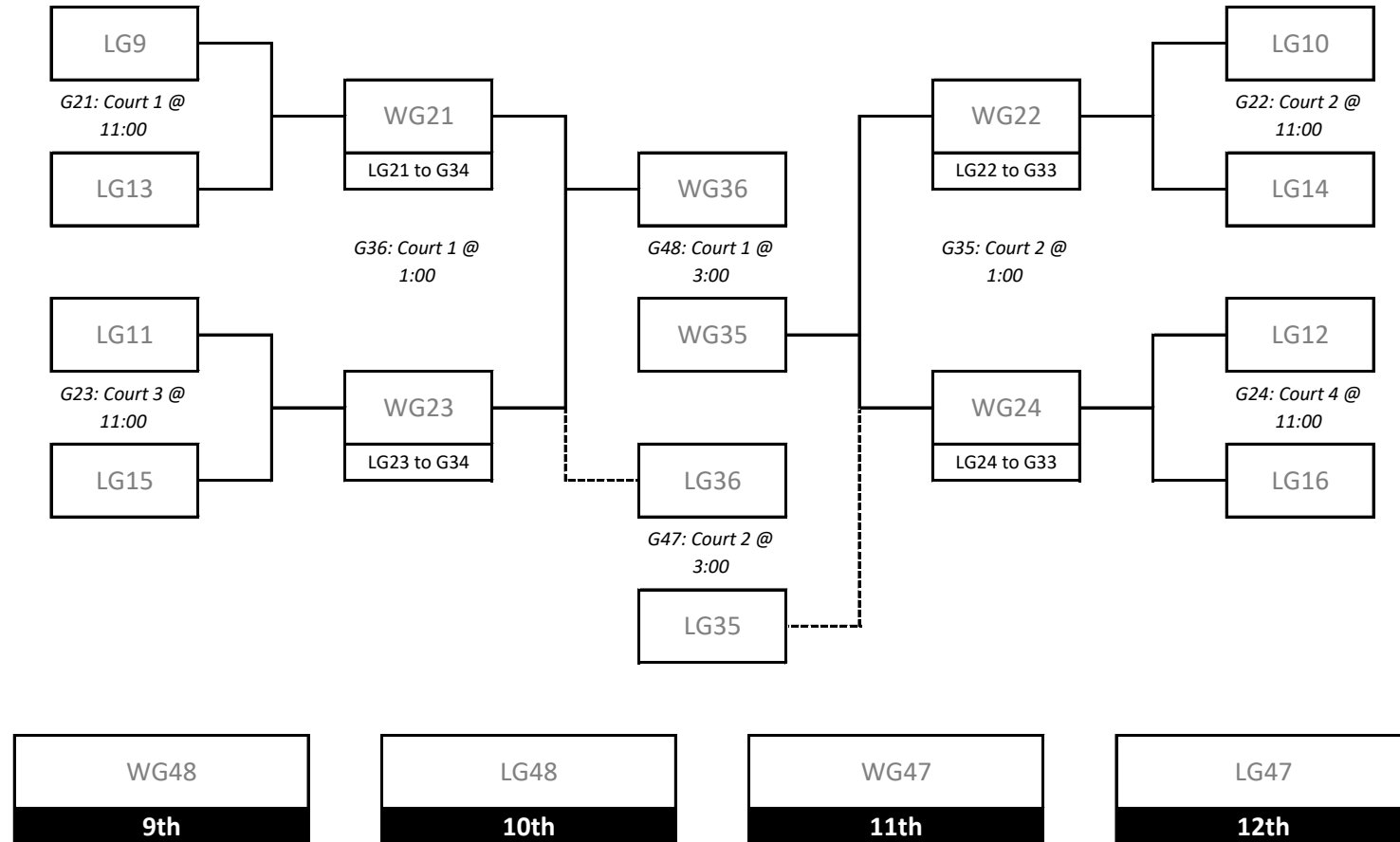

2024 13U Girls Provincial Championships

Saturday, May 4th and Sunday, May 5th
Dakota Community Centre



Playoff Bracket (17th-24th)

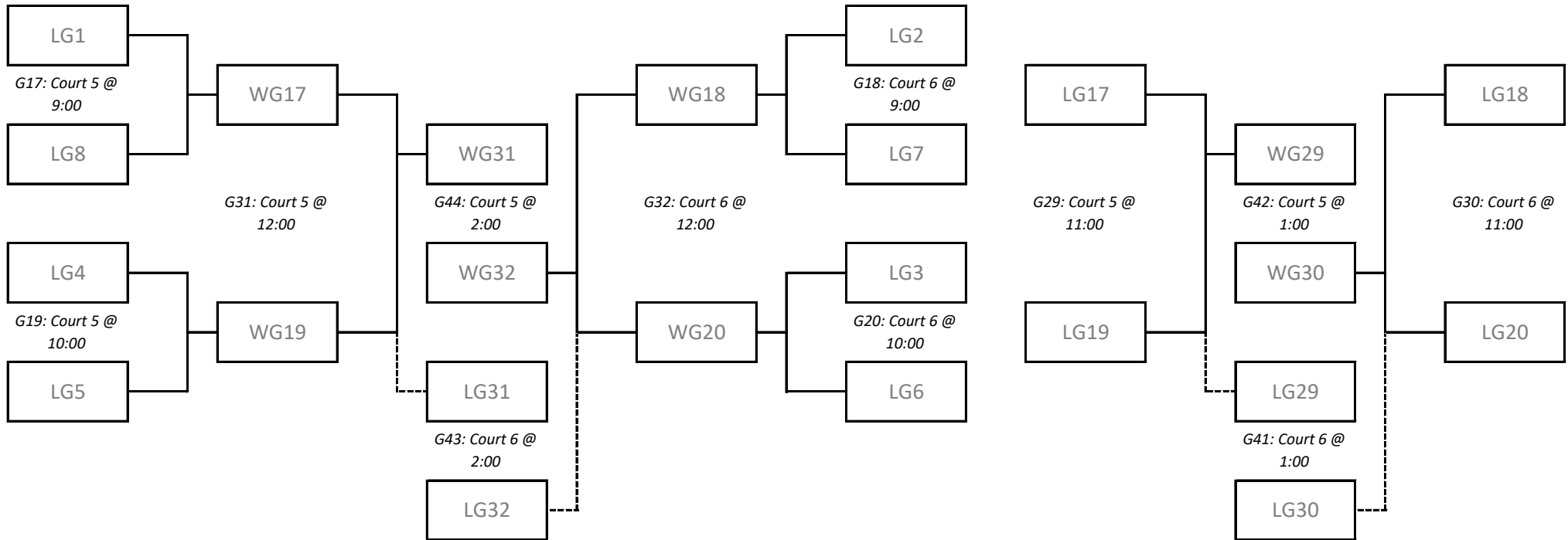

WG44	LG44	WG43	LG43	WG42	LG42	WG41	LG41
17th	18th	19th	20th	21st	22nd	23rd	24th



2024 13U Girls Provincial Championships

Saturday, May 4th and Sunday, May 5th
Dakota Community Centre



Tournament Format & Rules

All standard Volleyball Canada Age Class Rules will be observed, with the exception/inclusion of the following:

For each match, the competing teams will be required to provide 1 volunteer each to act as scorekeepers for the match
Volleyball Canada National Championship Warm-up Protocol **will be utilized** at Volleyball Manitoba Premier and Provincial Events

All matches will be played:

Best two-out-of-three sets

First two sets are to 25, win by 2, no cap

Third set (if necessary) is played to 15, win by 2, no cap

Two 30-second time-outs per team per set

Warm-ups will consist of:

- Minimum 4 minutes shared court

- 4 minutes Team A full court

- 4 minutes Team B full court

- "Digging warm-up" during opposing team's court time is not permitted

- Referees/Tournament Supervisors will have final say over warm-up times if the tournament is running behind

Playoff seeding will be determined by:

Total matches won

Please refer to the Volleyball Canada Rule Book for Tie-breaking procedures

If the event is running ahead of schedule, matches may start early as long as both teams and the referee(s) agree

Matches may not begin more than 30 minutes ahead of their scheduled start time

Coaches will receive wrist-bands in their team package at check-in; these wrist-bands must be worn in order to be on the bench

Please note: at the 13U Age Category, the following Age Class Specific rules apply:

- The Tripleball Game Format will be utilized
- Receiving Serve with an overhand motion using the fingers (volleying/setting the serve) is not permitted
- Liberos are not permitted; please see next page for roster and substitution rules
- 13U Boys Net height measures 2.20m
- The Mikasa VQ200W-can will be used



2024 13U Girls Provincial Championships

Saturday, May 4th and Sunday, May 5th
Dakota Community Centre



13U & 14U Roster & Substitution Rules

New this year, 14U and younger teams are required to have a minimum of 9 players on the score sheet in order to be eligible to participate in a match. No player will be eligible to participate in all three sets. Substitutions are not permitted in the first or second set. In the case of injury, an Exceptional Substitution may be made. The injured/ill player may not return to the same set but may return to play in subsequent sets. If a player is expelled or disqualified, there must be a legal substitution allowed for the set to continue. If a player is expelled in the first set, the expelled player may not start the second set but would be allowed to start the third set. **If a player has played in the first two sets, they will not be eligible to play in the third set.** In the third set, 12 unlimited substitutions are permitted among eligible players (i.e. players who have not played in both of the first two sets). Considerations may be made for injury/illness as appropriate.

Rationale:

The purpose of this rule is to remove the incentive of “shortening the bench” as a way around the VC Fair Play rules. This will put a team which has 9 players on the score sheet (or 10 or 11) in the same position as a team with 12, where they can only play any given player in two of three sets. This rule is being implemented on a one-year trial and will be re-evaluated for next season.

Please note that if a team has 12 players in attendance, this is not designed to allow that team to only list 9 on the game sheet. All available and able players should be included whenever possible. Referees should note in the Remarks section of the game sheet if it appears that a team is leaving healthy players on the bench off of the game sheet.

Enforcement:

Rosters and lineups should be confirmed by referees and scorekeepers prior to each set. This is especially important in the third set, to confirm that the lineup is legal (i.e. comprised completely of eligible players).

If, after the third set has begun, it is discovered that an athlete on the floor has already played in the first two sets, they will be treated as an ineligible player and the team will lose all points scored so far, with the opposing team keeping their points, plus gaining a point and service.

If, during the third set, a player who has played in the first two sets is subbed in, it will be treated as an illegal substitution (per rule 15.9 - VC Rule Book).

Teams with fewer than 9 players at a match:

We understand that during the course of a season / event, especially at the 13U and 14U age categories, athletes may need to miss games for other activities. It is our hope that with teams being required to roster 12 players, fielding at least 9 for any given match shouldn't be an insurmountable task.

If a player gets injured during a tournament and a team has fewer than 9 players available for a match, the match will proceed as normal through the first two sets, with all players on the game sheet required to start either the first or second set. Should the match reach a third set, the team with fewer than 9 will be required to start all players who have only participated in one set so far, and choose the additional starters from their remaining players on the game sheet. The opposing team will be exempt from the “2-set-maximum” rule and be able to play any lineup they wish in the third.